

The CHARA Delay Lines Performance Status

Narsireddy Anugu
+ CHARA

2024 Mar 13

Introduction

- S1 visibility loss problem (solved)
- High RMS errors (pending)

Huge efforts

- Spent months and months of time
- Developed several tools and power spectrum plots to understand the problem
- Played with how we communicate with carts (velocity mode, ramp mode)
- Several nights of on-sky time to understand S1 visibility problem
- Create lab fringes and move the delay lines to understand the S1 problem

S1 visibility problem

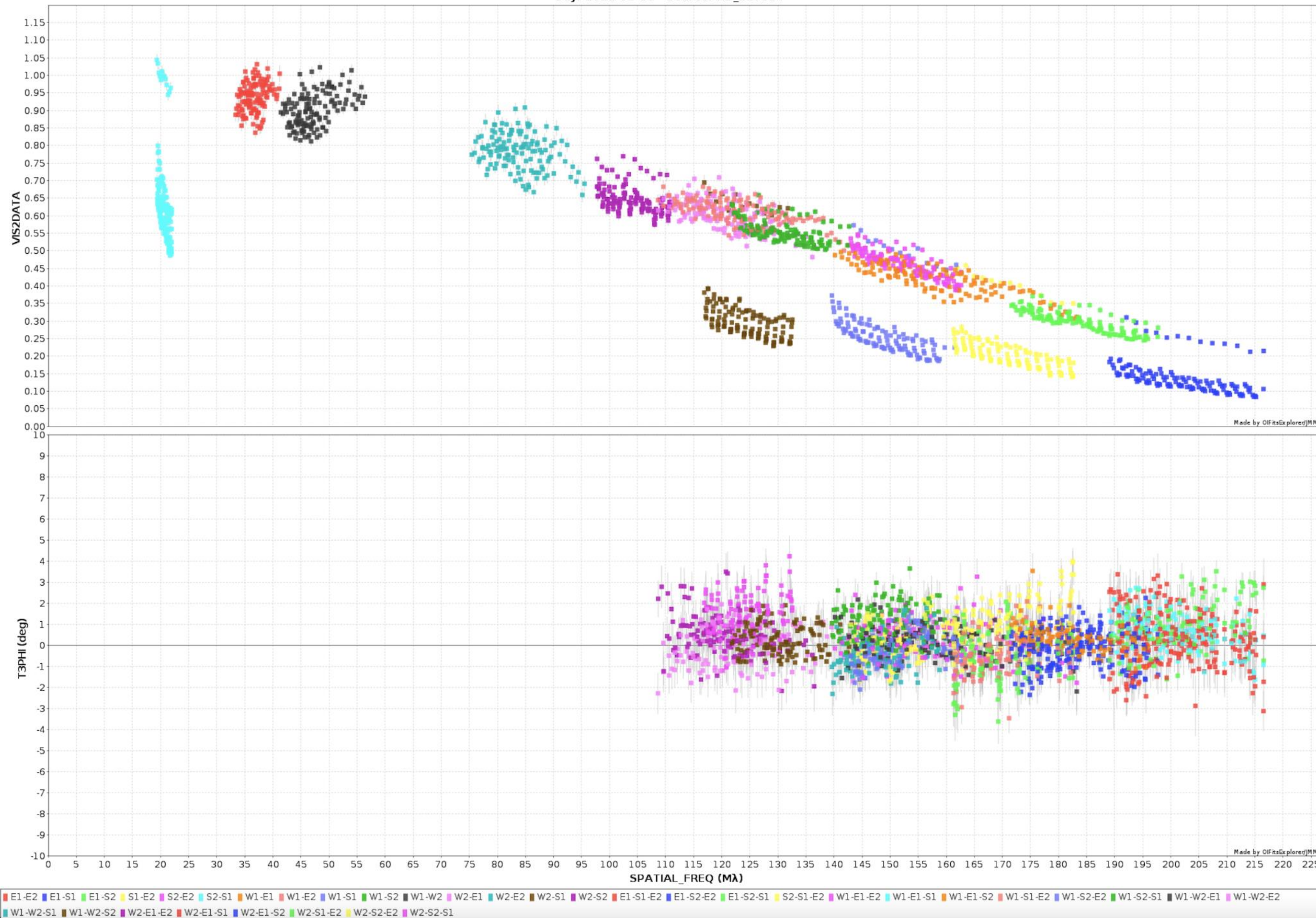

S1 visibility (solved on Oct 19, 2023)

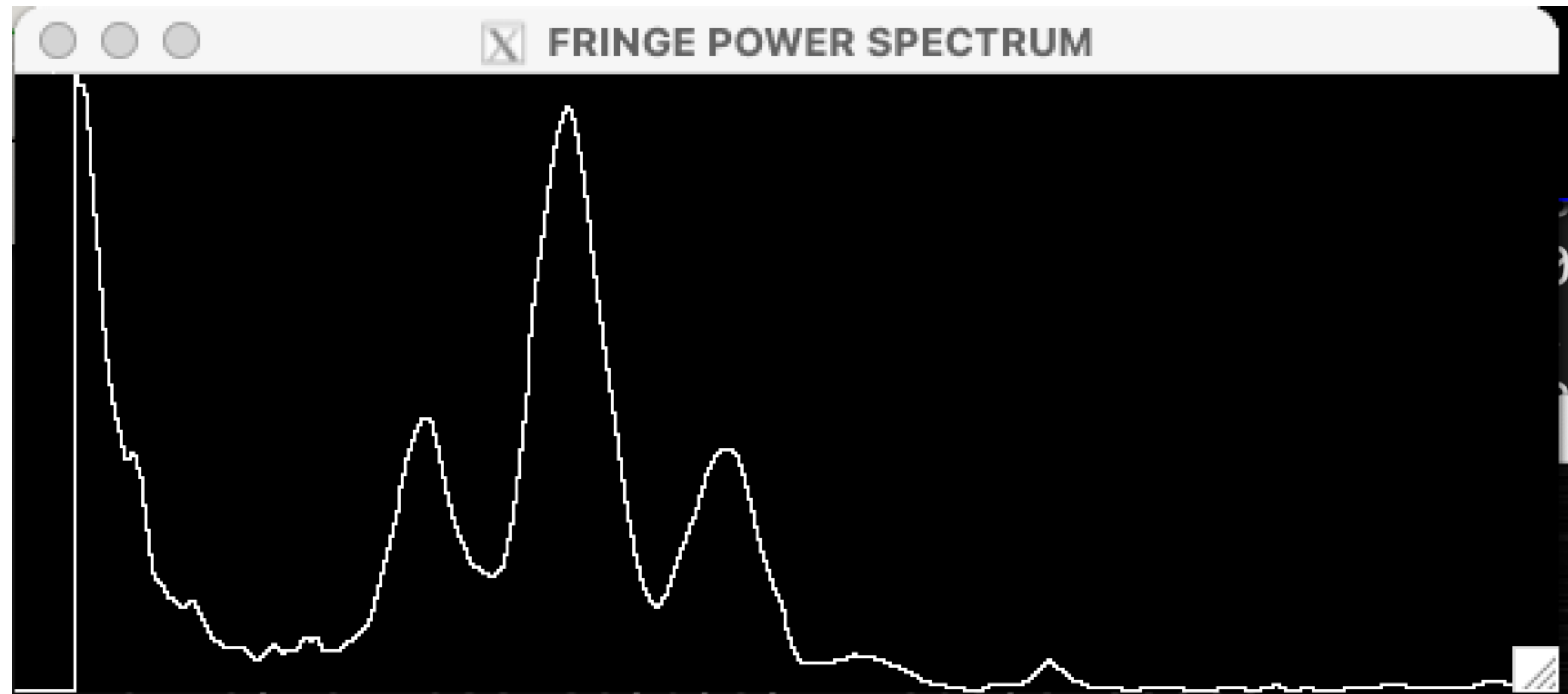
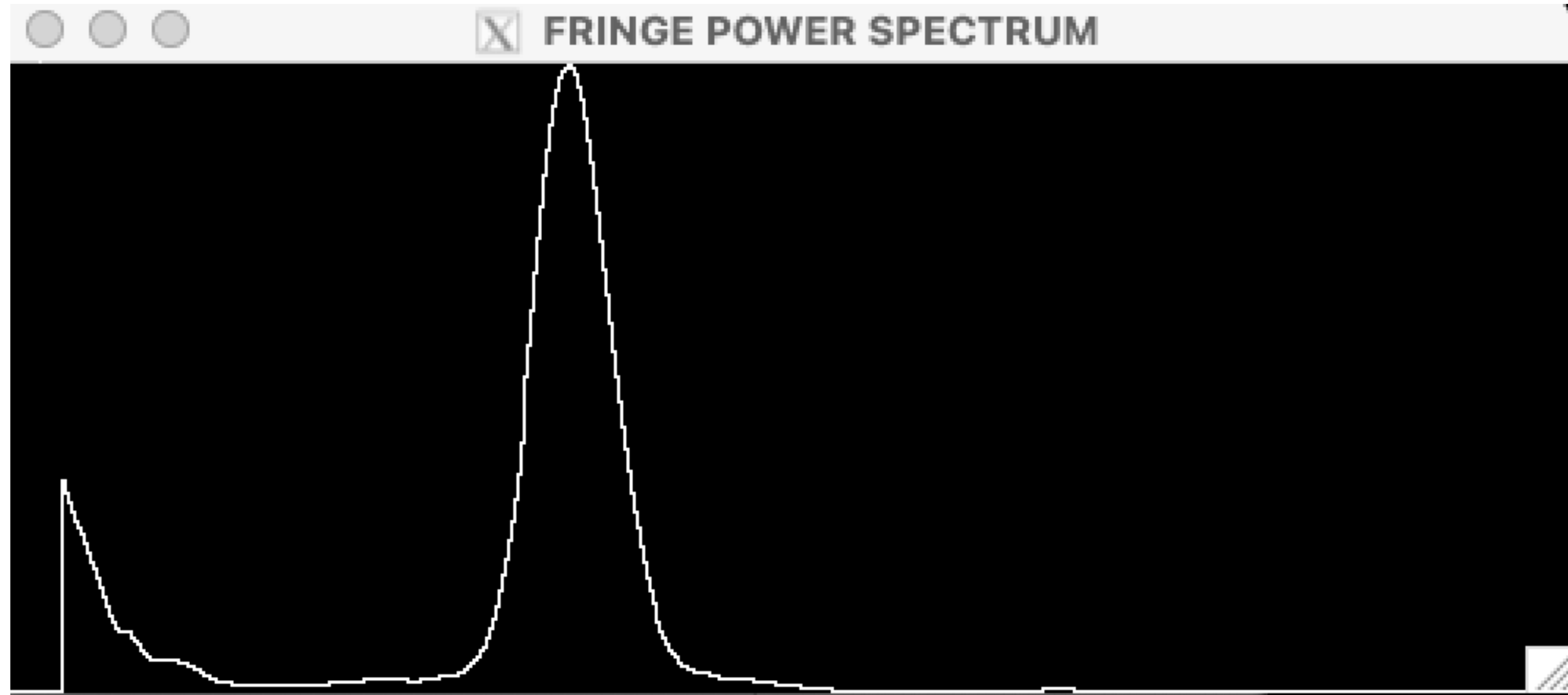

Understanding the source of errors

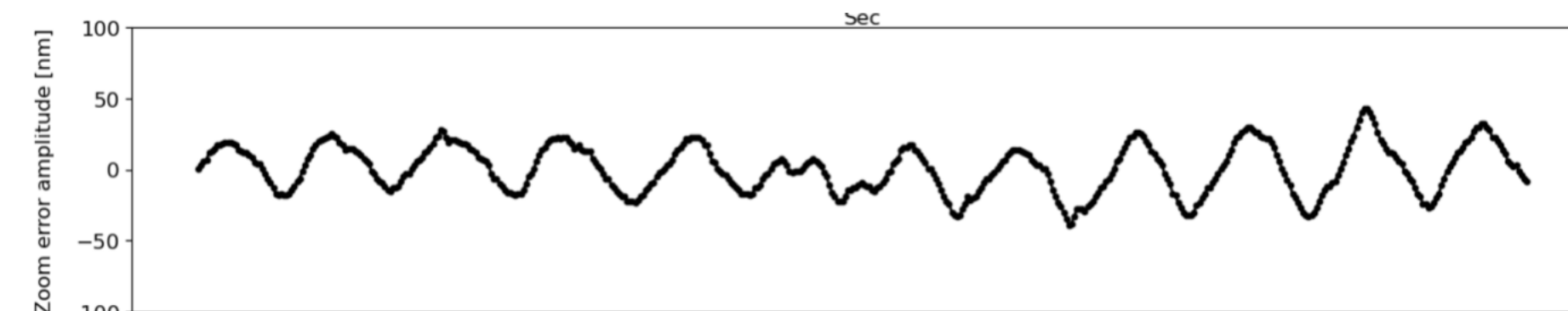

(A) Not moving or tracking target position

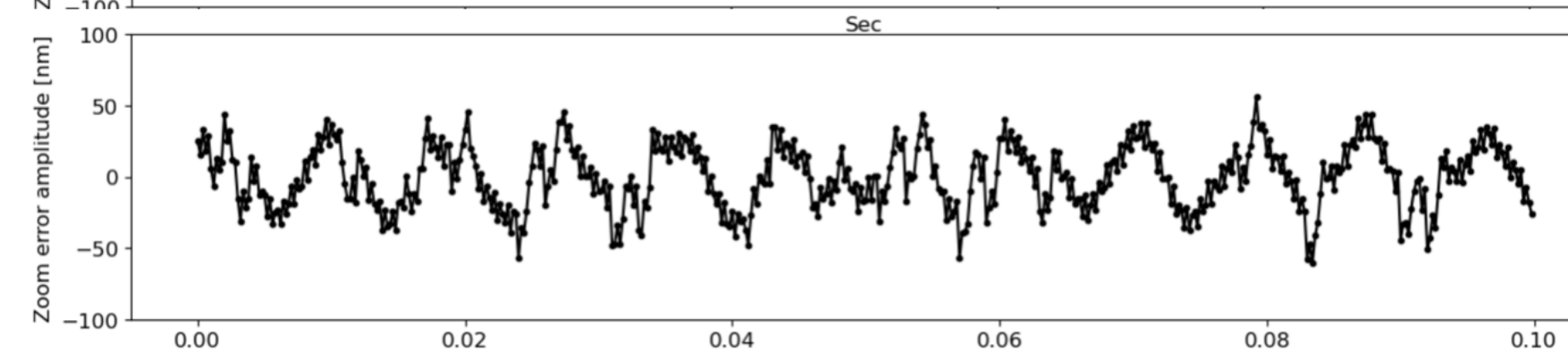

(B) Moving 1.5 mm/s

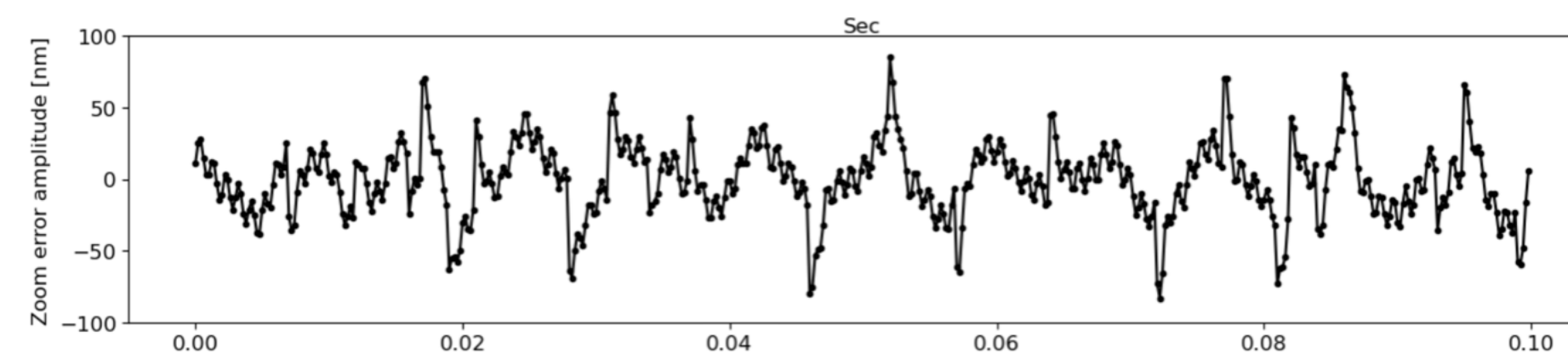

(C) Moving 2 mm/s, started to see extra vibrations

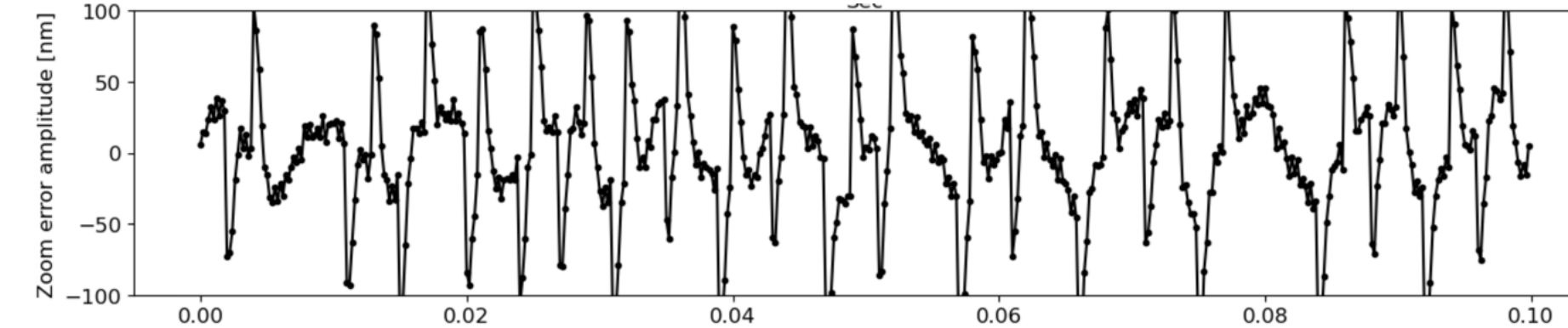

(D) Moving 4 mm/s

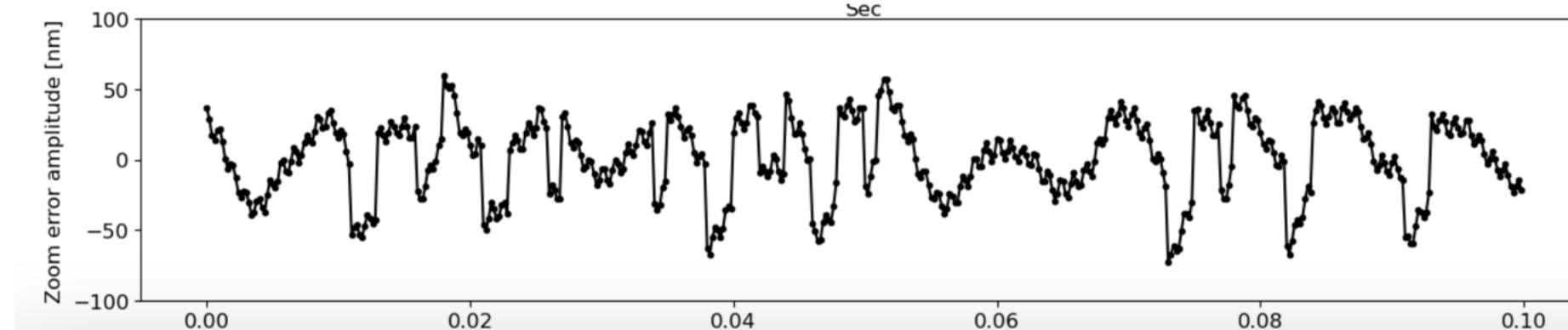

(E) Moving 4 mm/s but with my new gains

E1 voice coils

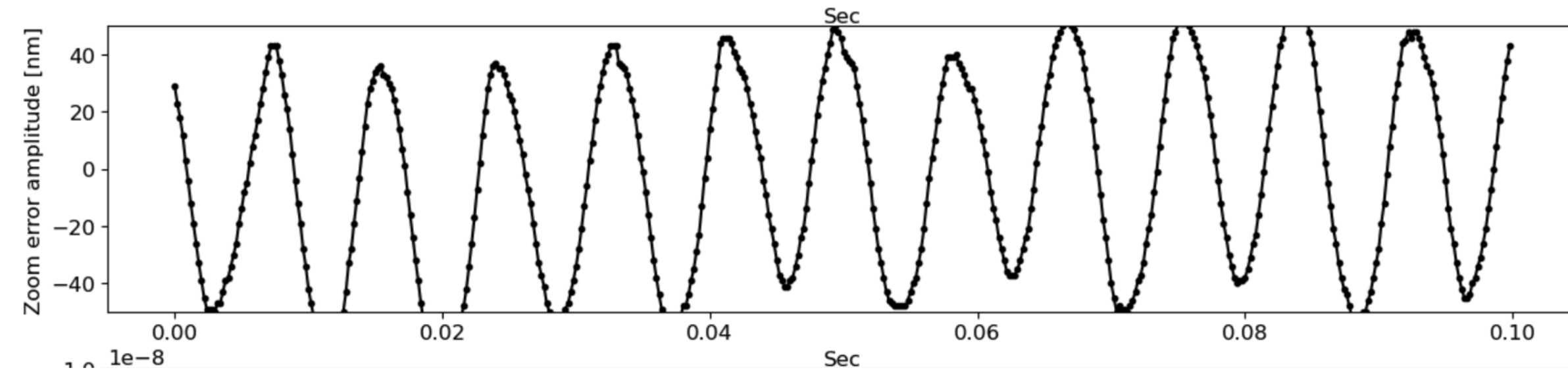

E1

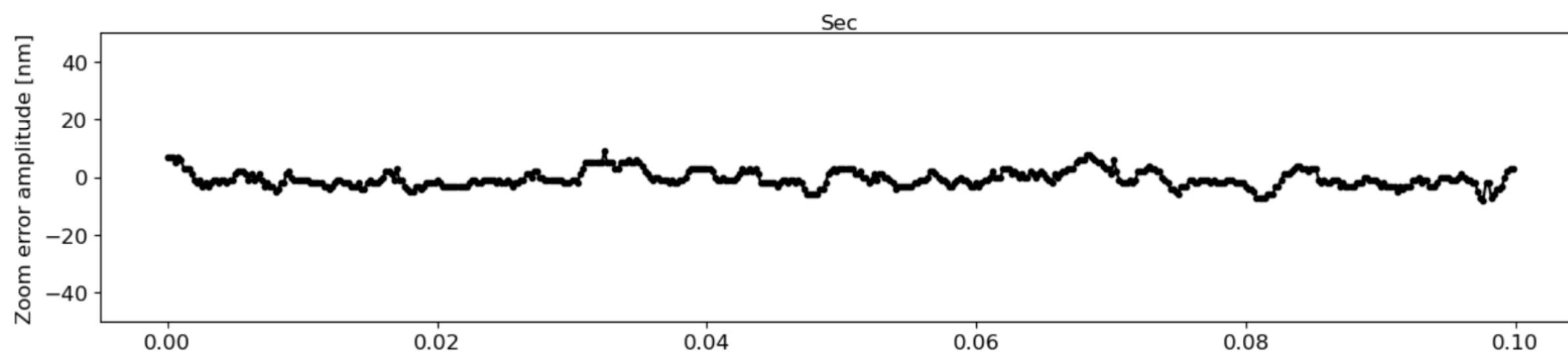

E1 - fixed
with voice coil gains

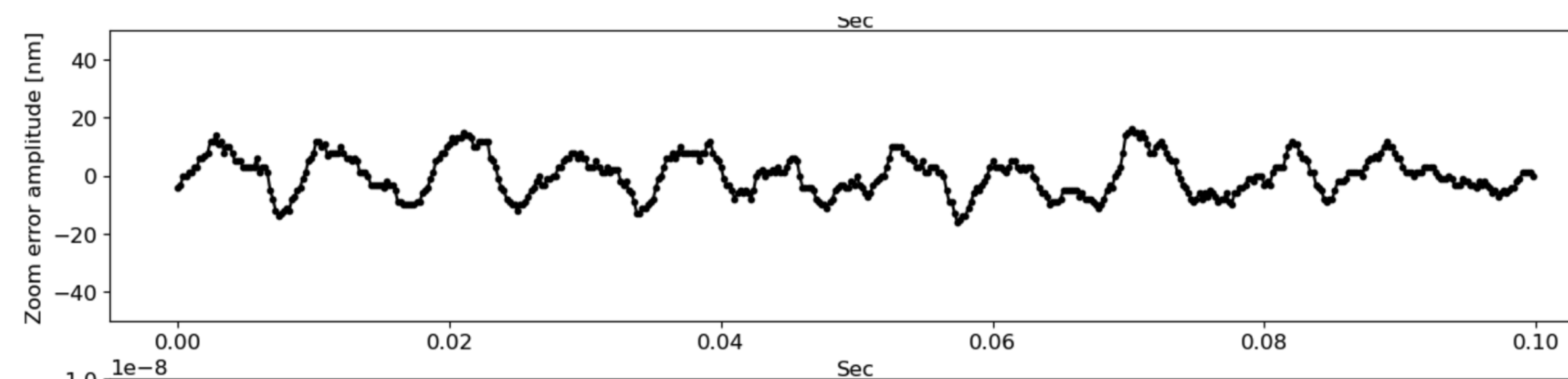

E2

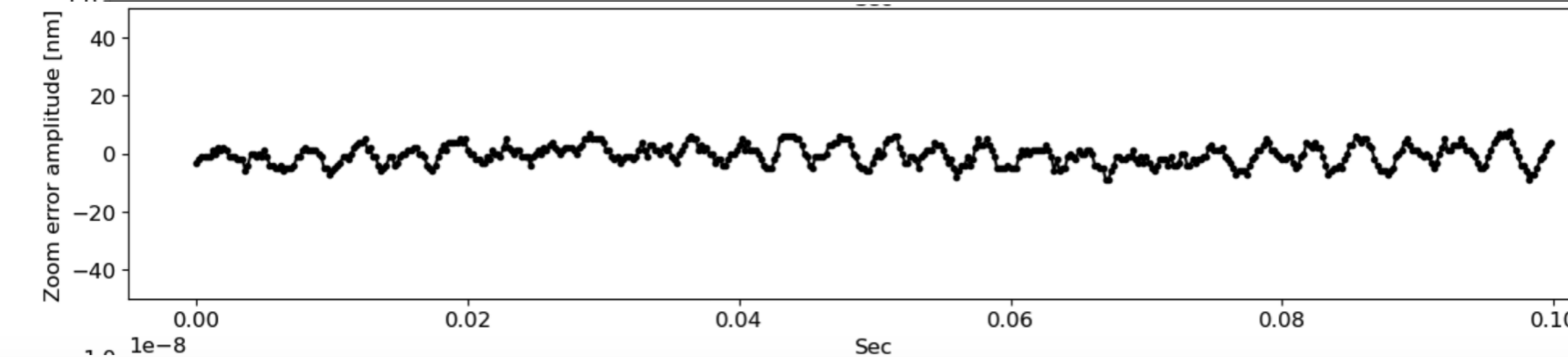

W1

E1 voice coils

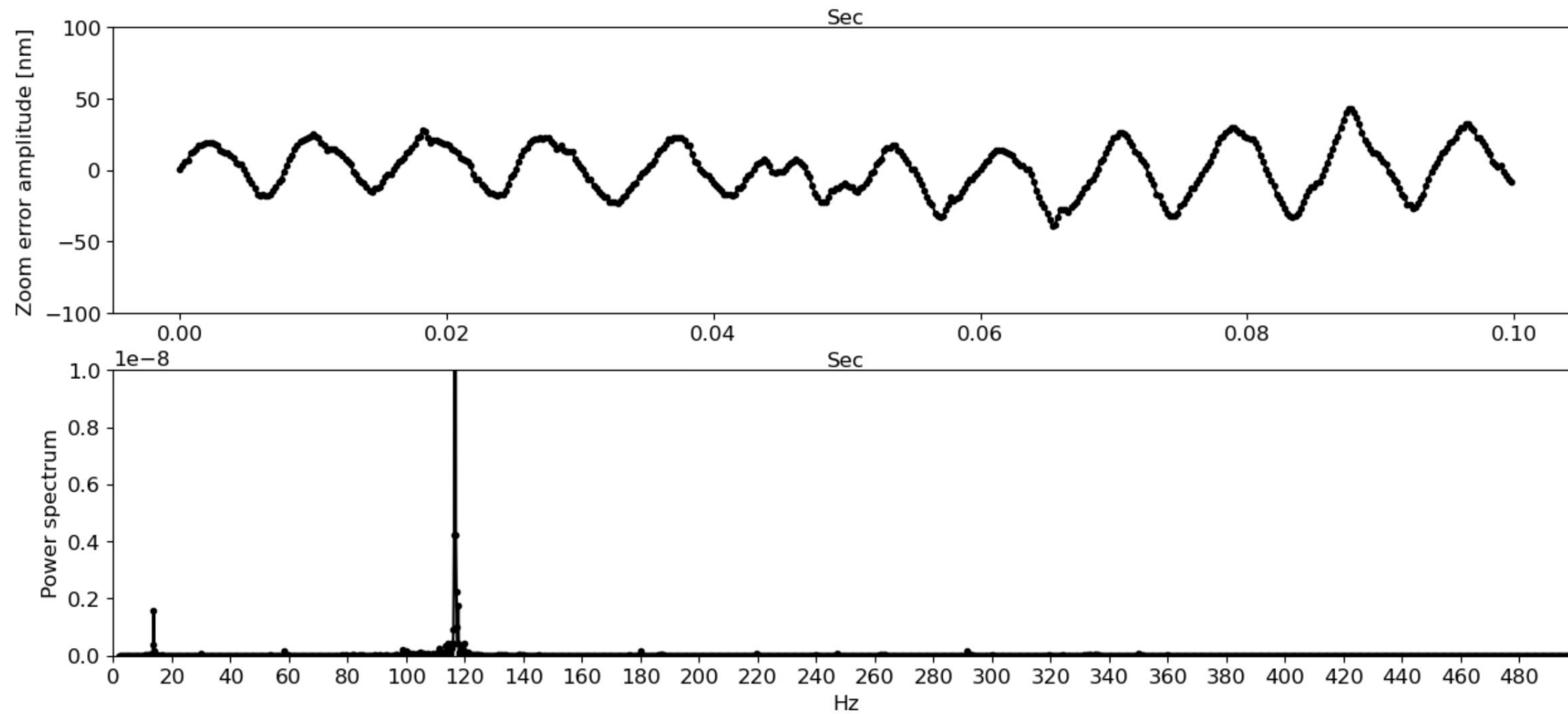

Swapped E1 Techron
in place of E2 not solved

Seems to be happening on the cart.
Needs more work identify

Four stage control

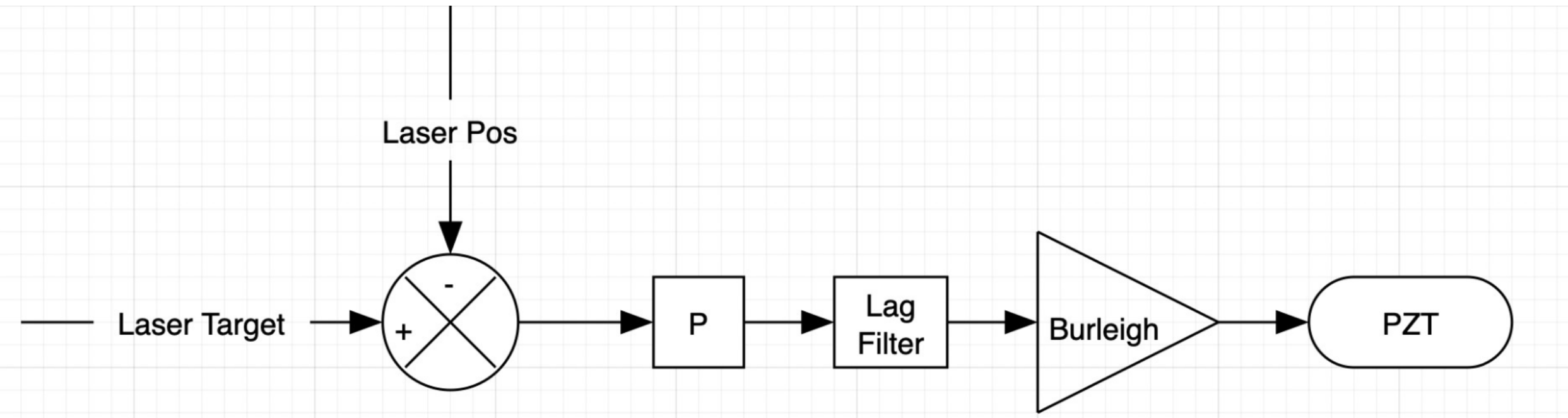
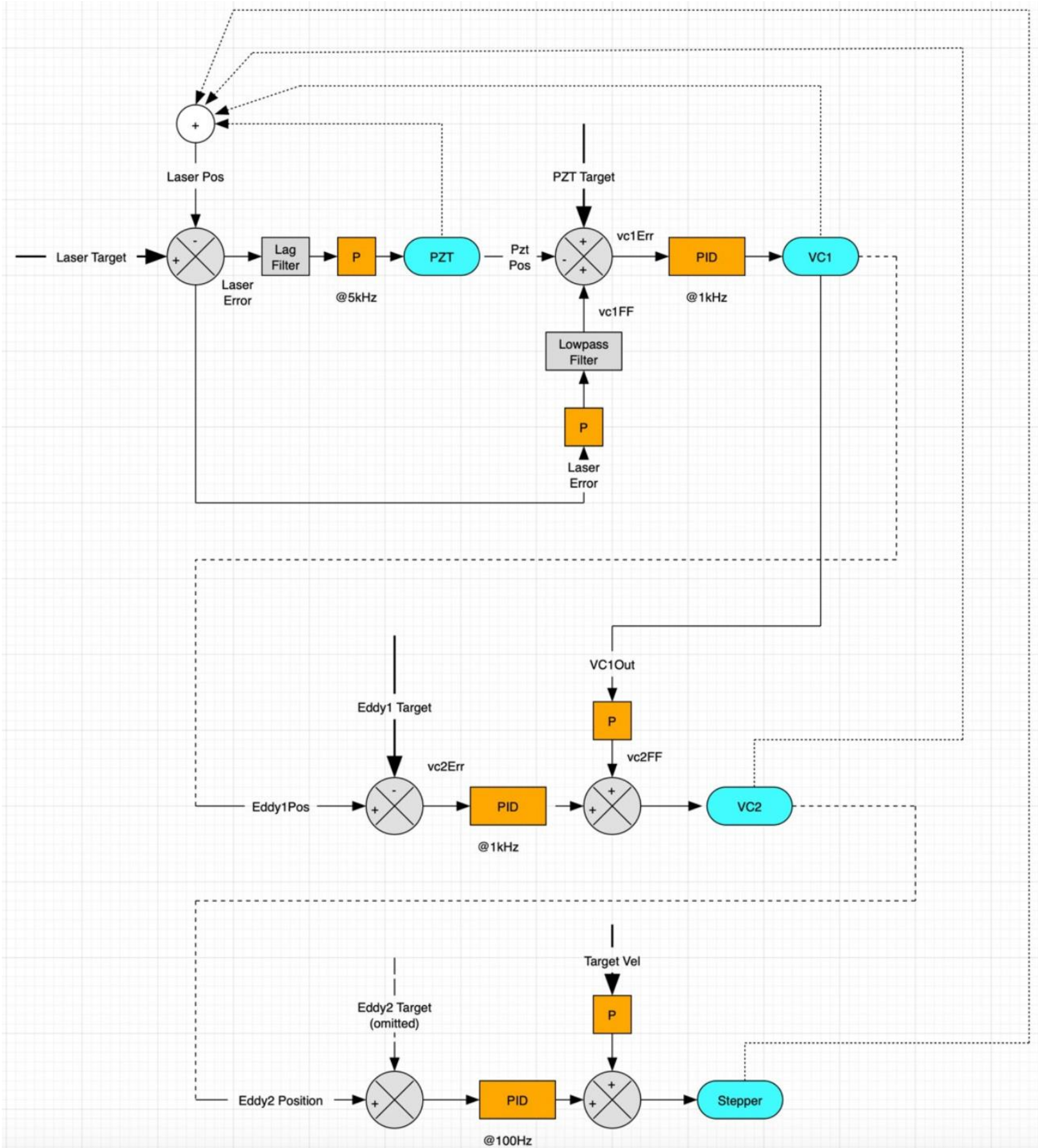

Four stage control:

(1) PZT

(2) Voice coil 1

(3) Voice coil 2

(4) Stepper motor

Digital spikes in target

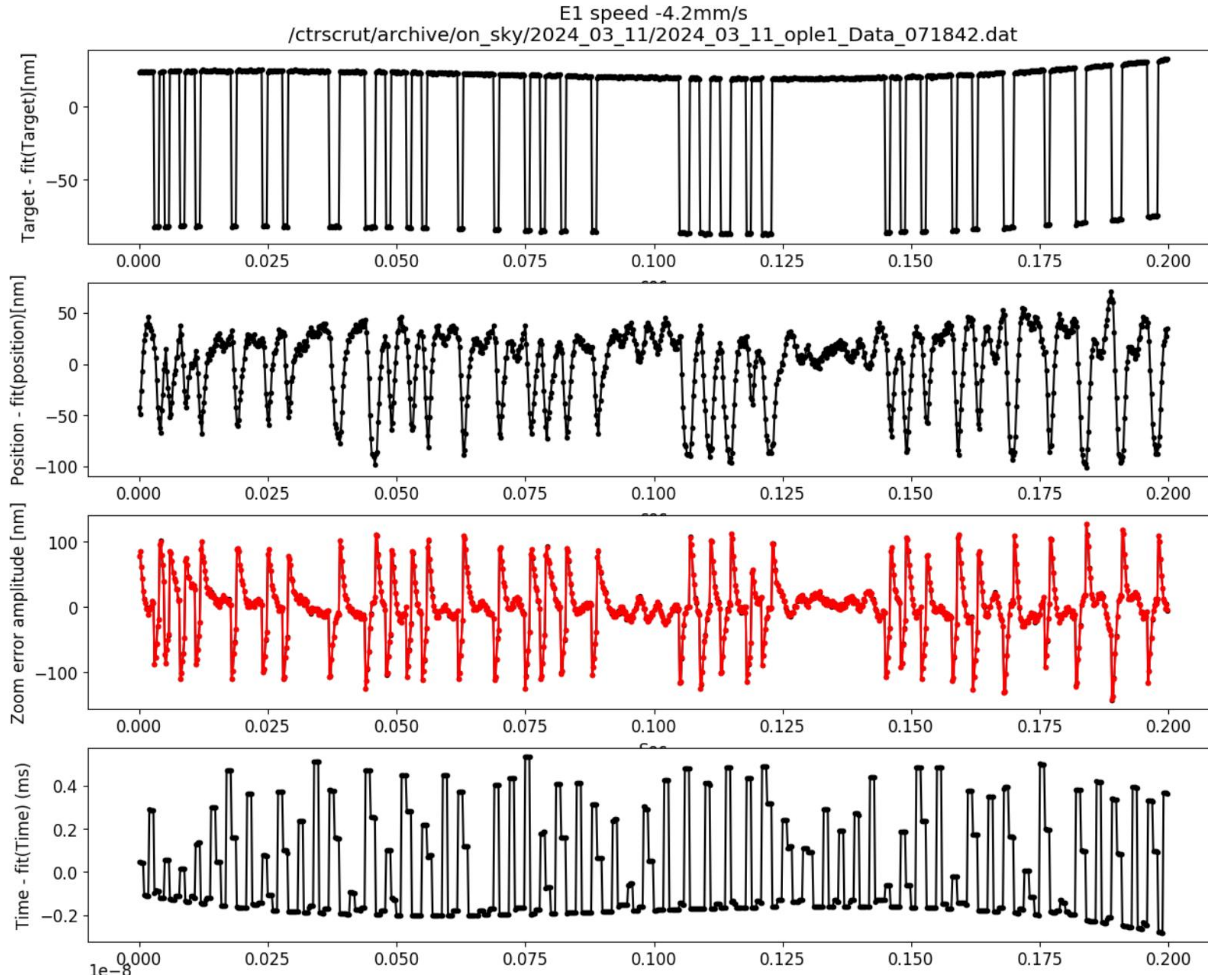

Missing 25 us tick

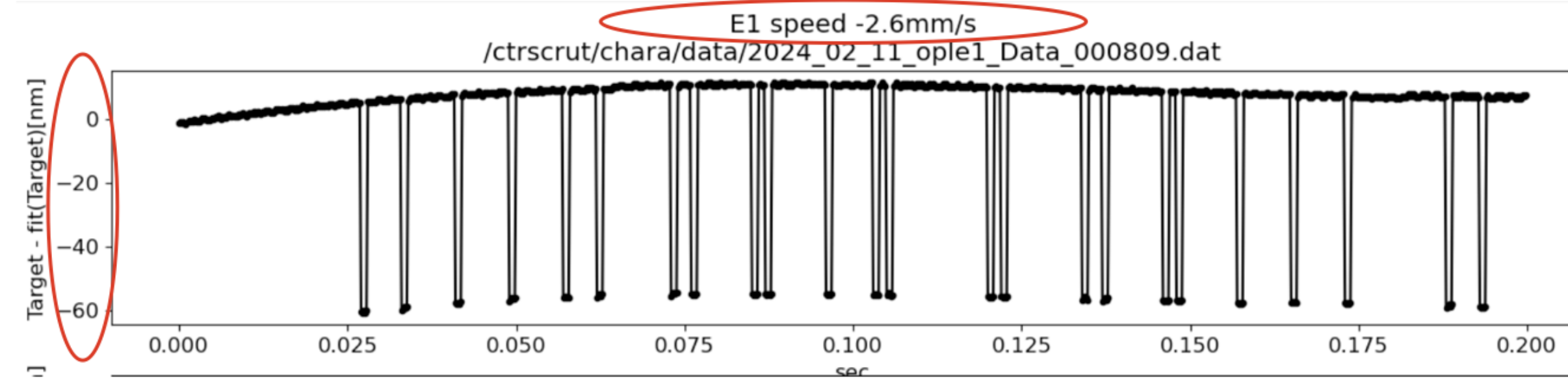

$$65e-9 / 2.6e-3 * 1e6 = 25\mu s$$

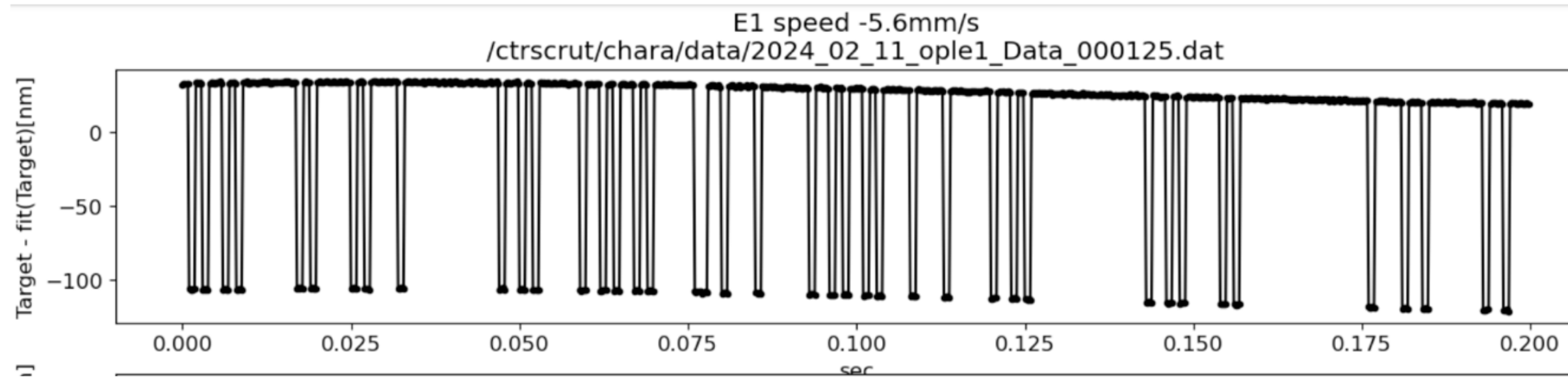

$$140e-9 / 5.6e-3 * 1e6 = 25\mu s$$

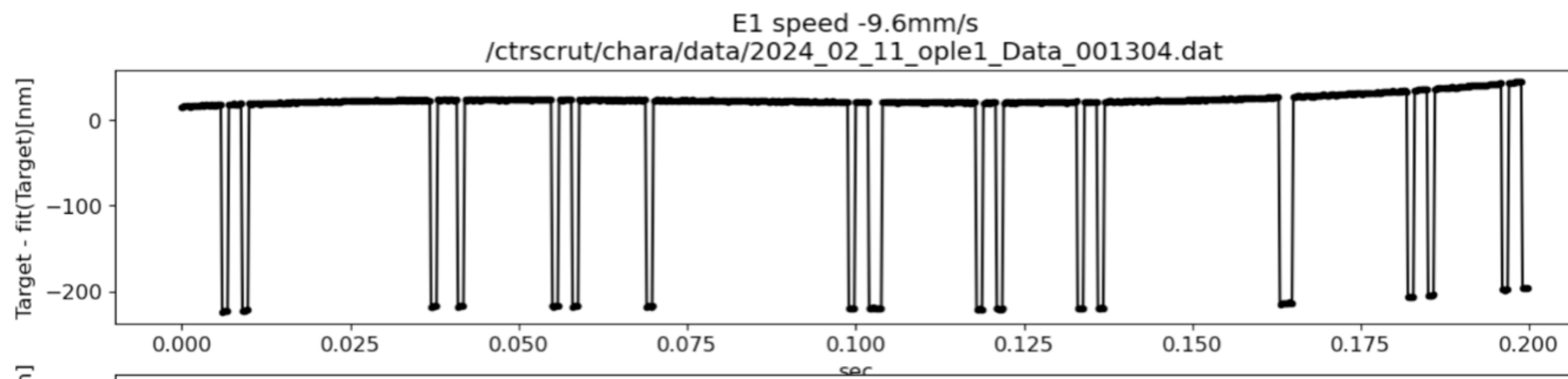

$$240e-9 / 9.66e-3 * 1e6 = 25\mu s$$

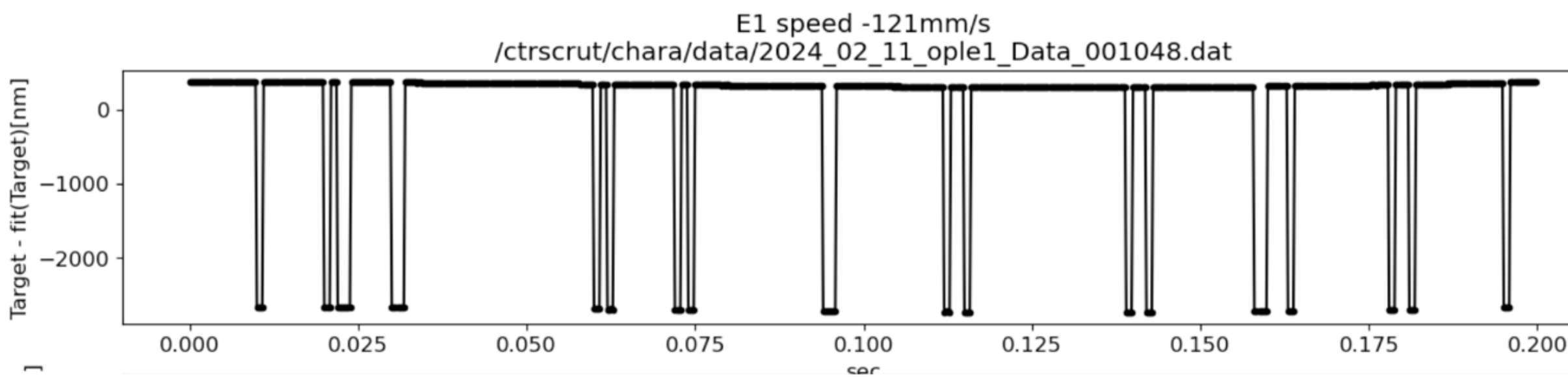

$$3000e-9 / 120e-3 * 1e6 = 25\mu s$$

How it is computed?

16 MHz signal

1 Hz signal

25 us ticks scheduler

40K Kz loop



16 MHz clock calibration checks

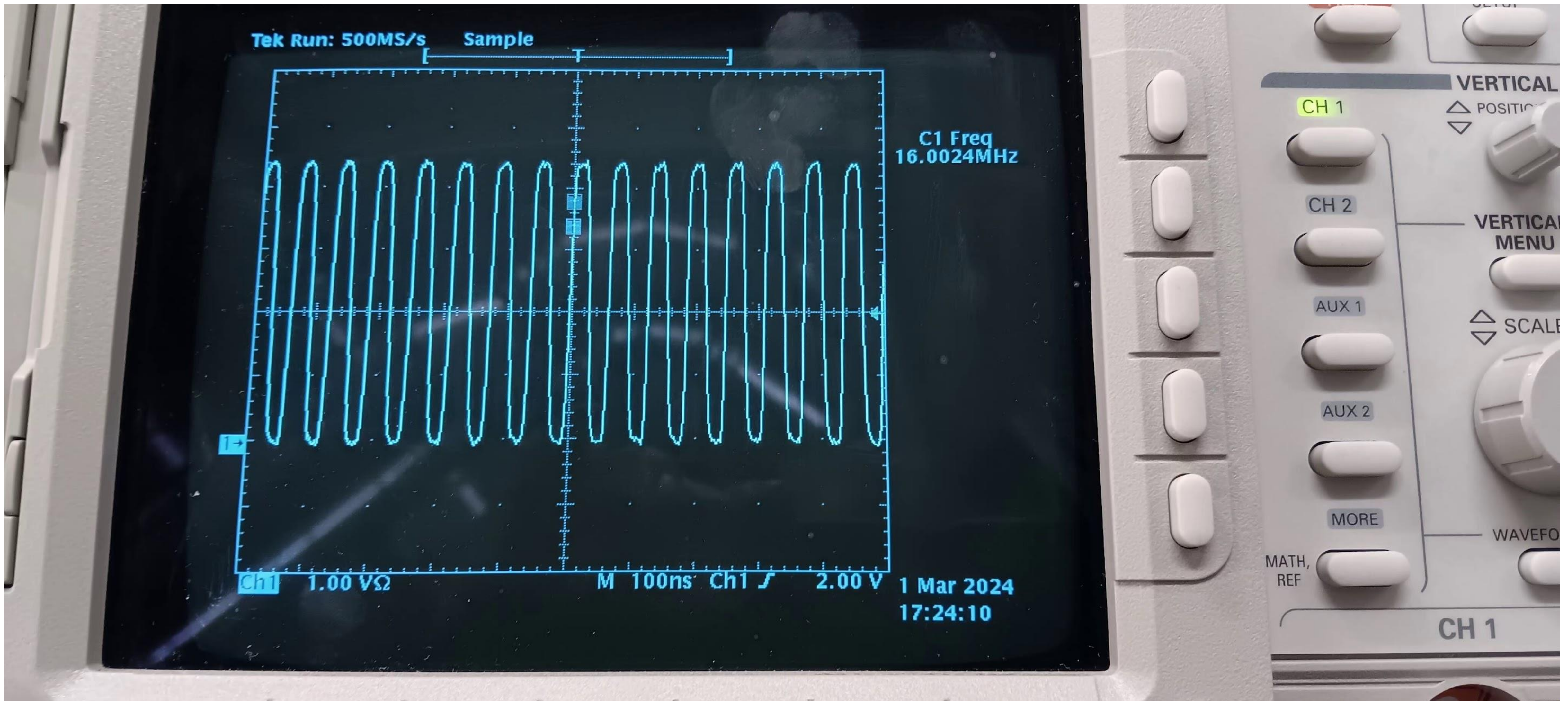

Checked with signal generator

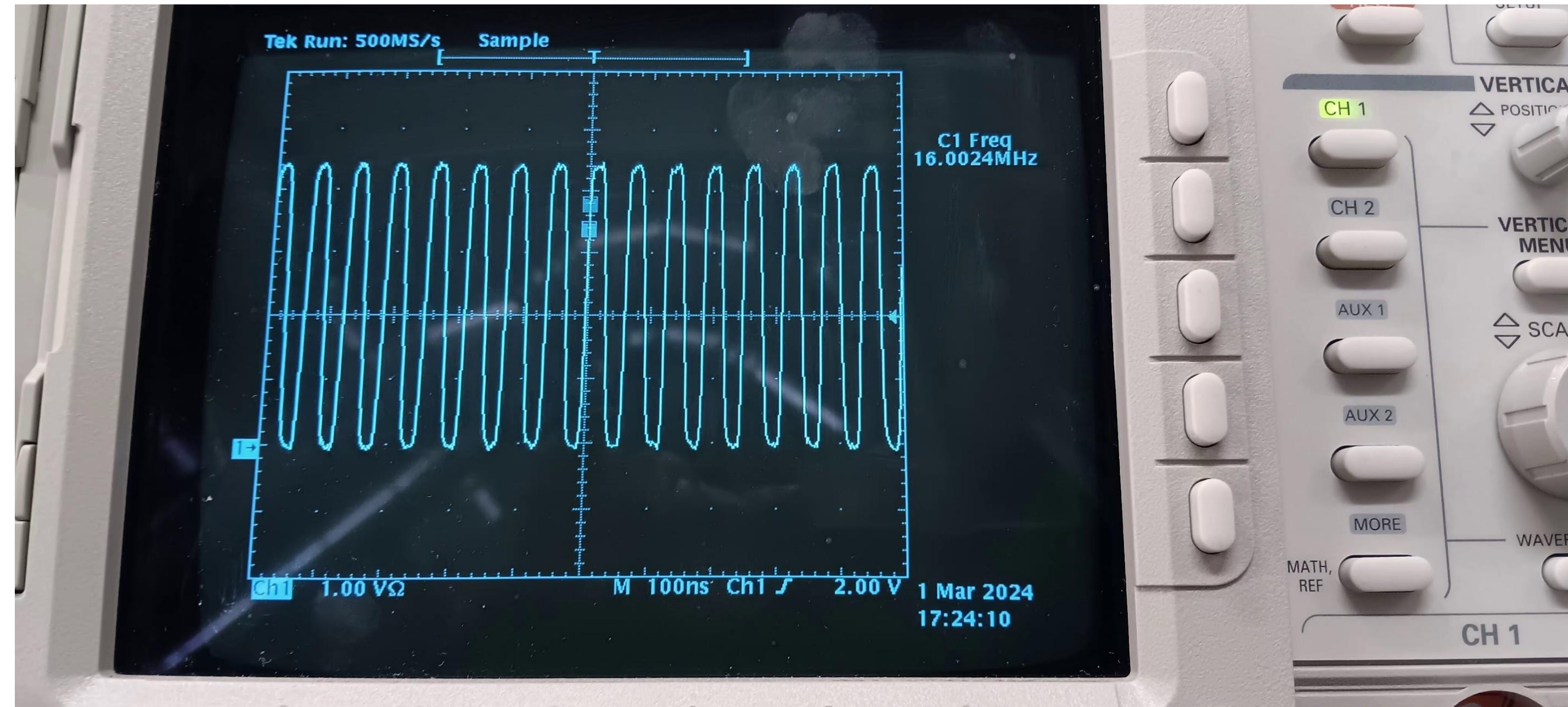

Generated signal



Signal generator

Temporary/intermediate fix?

